

**IPRK 18**

**Retro-reflective photoelectric sensors with analog output**

en 04-2014/05 50110544-01



**0 ... 1m**

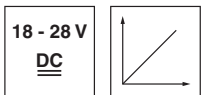

- Analogue output signal 4 ... 20mA
- Teach-in for adaptation to the application

**Dimensioned drawing**

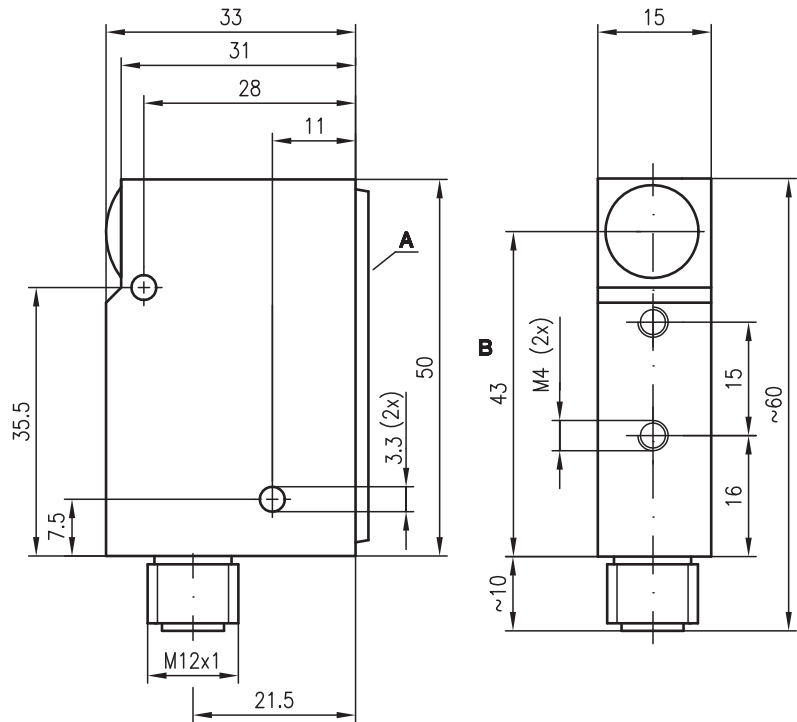

- A** Indicator diodes
- B** Optical axis

**Electrical connection**

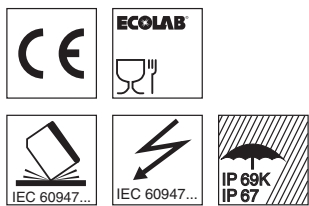
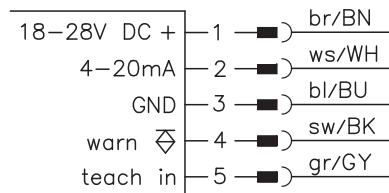

**Accessories:**

(available separately)

- Mounting system (BT 95)
- M12 connectors (KD ..., K-D ...)
- Reflectors

We reserve the right to make changes • DS\_IPRK18V\_en\_50110544\_01.fm

## Specifications

### Optical data

Typ. operating range limit (MTKS 50x50) <sup>1)</sup>	0 ... 1.2m
Operating range <sup>2)</sup>	see tables
Recommended reflector	MTKS 50x50.1
Light source	LED (modulated light)
Wavelength	660nm (visible red light, polarized)

### Timing

Update time (analog output)	2ms
Delay before start-up	≤ 300ms

### Electrical data

Operating voltage $U_B$	18 ... 28VDC (incl. residual ripple)
Residual ripple	≤ 15% of $U_B$
Open-circuit current	≤ 60mA
Analog output	4 ... 20mA non-linearized, $R_L \leq 1\text{ k}\Omega$ , 4mA with interrupted light path, 20mA with free light path, 12mA after teach-in
Resolution of analog output	1% of the maximum value (20mA)
Warning output	PNP
Function of warning output	see options
Teach input	PNP
Function of teach input	see options

### Indicators

Green LED, continuous light	voltage supply
Red LED, continuous light	error
Yellow LED, continuous light	light path free

### Mechanical data

Housing	diecast zinc
Optics cover	glass
Weight	150g
Connection type	M12 connector, 5-pin, stainless steel

### Environmental data

Ambient temp. (operation/storage)	-25°C ... +55°C/-40°C ... +70°C
Protective circuit <sup>3)</sup>	2, 3
VDE safety class	III
Protection class	IP 67, IP 69K <sup>4)</sup>
Light source	free group (in accordance with EN 62471)
Standards applied	IEC 60947-5-2

### Options

#### Warning output

Signal voltage high/low <sup>5)</sup>	PNP, static principle
Output current	$\geq (U_B - 2V) \leq 2V$
Functions	max. 100mA
No error	warning output = high
Teach-in without error	warning output = high
Hardware device error	warning output = low
Dynamic error	warning output = low
	(received signal level outside of permissible range)
Teach-in running	warning output = low
Teach input	PNP
Teach-in active/not active	$U_B/0V$ or not connected
Teach time	$\geq 20\text{ms}$ (analog output supplies measurement value)
Handshake	warning output acknowledges the teach event

- 1) Typ. operating range limit: max. attainable range without performance reserve
- 2) Operating range: recommended range with performance reserve
- 3) 2=polarity reversal protection, 3=short circuit protection for all outputs
- 4) IP 69K test acc. to DIN 40050 part 9 simulated, high pressure cleaning conditions without the use of additives, acids and bases are not part of the test
- 5) Functional extra-low voltage with reliable disconnection or protective extra-low voltage (VDE 0100/T 410)

## Order guide

Selection table		IPRK 18/V L.03 Part no. 50106974					
Order code →							
Equipment ↓							
Switching output	1 PNP warning output	●					
Analog output	4 ... 20mA	●					
Options	Teach via control cable	●					

## Tables

Reflectors		Operating range	
1	MTKS 50x50.1	0 ... 1.0m	
2	Tape 6 50x50	0 ... 1.0m	

1	0	1.0	1.2
2	0	1.0	1.2

Operating range [m]  
 Typ. operating range limit [m]

MTKS ... = screw type

## Teach-in process

1. Align sensor with reflector.  
The beam must not fall outside the reflector area!
2. Place the object to be scanned in the beam path.
3. Perform teach-in (teach-in input low -> high -> low).
4. Following teach-in, analog output exhibits approx. 12mA.

## Remarks

### Operate in accordance with intended use!

- ⚠ This product is not a safety sensor and is not intended as personnel protection.
- ⚠ The product may only be put into operation by competent persons.
- ⚠ Only use the product in accordance with the intended use.

- Following successful teach-in, the sensor supplies approx. 12mA.
- The analog output supplies a measurement value even in the event of an error.
- The light spot may not exceed the reflector.
- Preferably use MTK(S) or tape 6.
- For foil 6 the sensor's side edge must be aligned parallel to the side edge of the reflective tape.